

Small capacity air pump

CD-8S



Pressure & vacuum Type

Built-in use

*No power plug included because it is designed for built-in use.

*Rubber-made legs are sharp-pointed. Not for self-standing installation.

Applications

- Air mat, air bed (continuous air exhaust)
- Air bearing
- For burner (air supply)
- Scientific & chemical instruments (analysis and agitation)

Dimensions

(unit : mm)

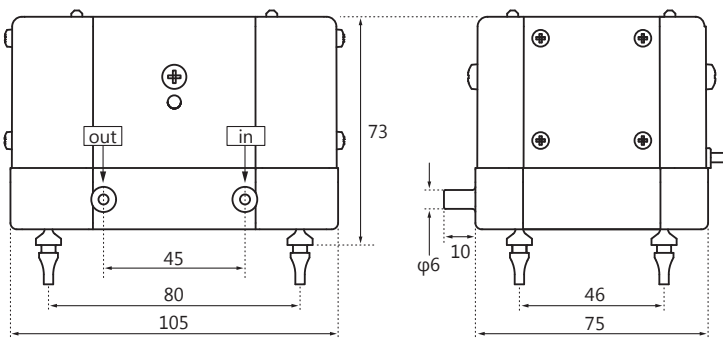

Specifications

	CD-8S	
Rated voltage [V]	AC100 / 120 / 230	
Power frequency [Hz]	50	60
Max airflow volume [L/min]	13 (-12)	17 (-16)
Max power consumption [W]	8	11
Sound level [dBA]	31	34
Weight [kg]	0.74	

*The value in parentheses represents vacuum.

*Sound data shown is with pump operating at 4kPa(C-5BN) / 5kPa(C-15H).

Performance Curve

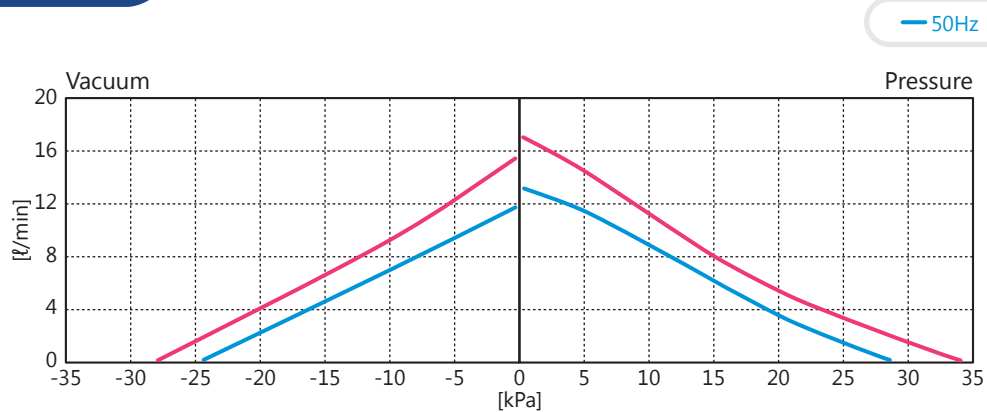

* All characteristics values are only for reference, and are not guaranteed values.

* Note that the operating temperature for our pumps is 41°F(5°C) to 104°F(40°C).