

Gas booster blower

FC-2030G



Pressure Type

Built-in use

*No power plug included because it is designed for built-in use.

*Rubber-made legs are sharp-pointed. Not for self-standing installation.

Applications

- Fuel cell system

Dimensions

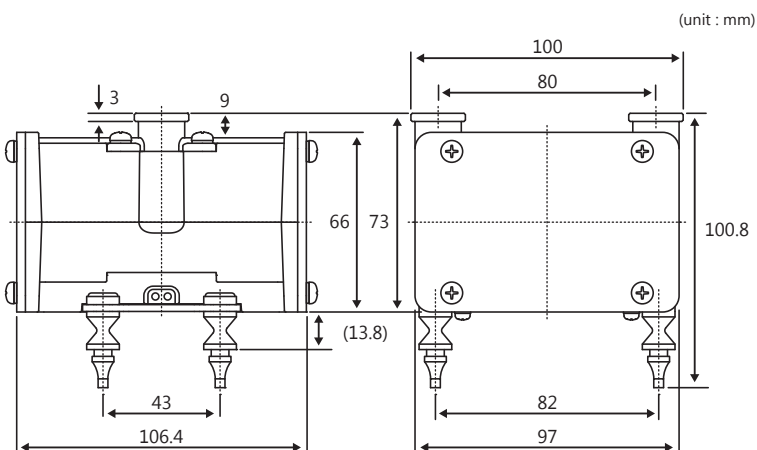

Specifications

Fluid	City gas, LPG	
Rated voltage	AC17V	
Frequency	60Hz	
	<PRESSURE>	<AIRFLOW>
Rated operating cond.	15kPa (150mbar)	4.0NL/min
Max operating cond.	25kPa (250mbar)	5.5NL/min
Min operating cond.	5kPa (50mbar)	0.4NL/min
Power consumption	4.0W ^(*1)	
Noise level	33dBA or less ^(*1)	
Size	0.82L ^(*2)	
Weight	1.42kg ^(*2)	
Gas sealing	0.3mL/min or less (@20kPa)	

*1: Without AIRTRONICS control driver.

*2: With AIRTRONICS control driver.

Performance Curve

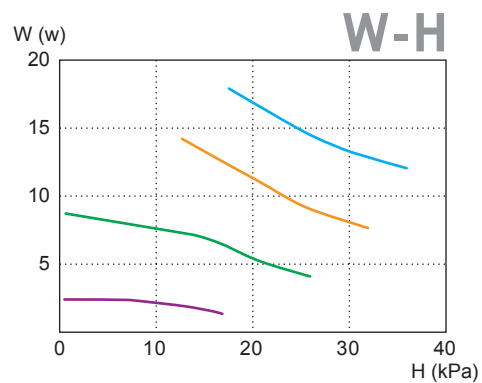
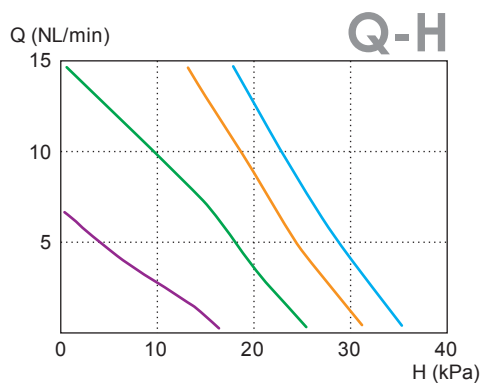

Control voltage

- 5V
- 4V
- 3V
- 2V

* Performance curves mentioned above are reference values by operation with Airtronics control driver.

* All characteristics values are only for reference, and are not guaranteed values.

* Note that the operating temperature for our pumps is 41°F(5°C) to 104°F(40°C).