

Small & medium capacity air pump  
**XP-40 / 60 / 80**



- Pressure type
- Dust control "Dust trap filter"
- Easy restart by micro switch (XP-60 / 80 only)
- No need of grounding
- Outdoor (Rainproof) use

Applications

- Septic tank (biological contact aeration)
- Air injection for bubble bath
- Small capacity compressor

Dimensions

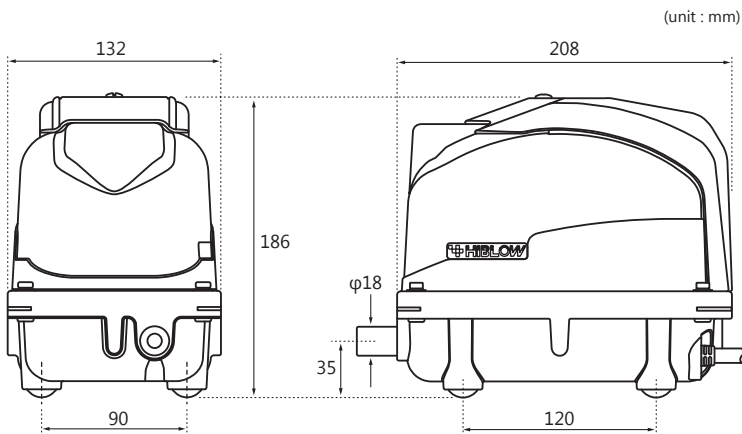

Specifications

	XP-40	XP-60	XP-80
Rated voltage [ V ]	AC100 / 120 / 230		
Power frequency [ Hz ]	50 / 60	50 / 60	50 / 60
Rated pressure [ kPa ]	12.8	14.7	14.7
Airflow volume [ L/min ]	40	60	80
Power consumption [ W ]	30	39	43
Sound level [ dBA ]	33	35	35
Weight [ kg ]	4.1	4.3	4.3

Performance Curve

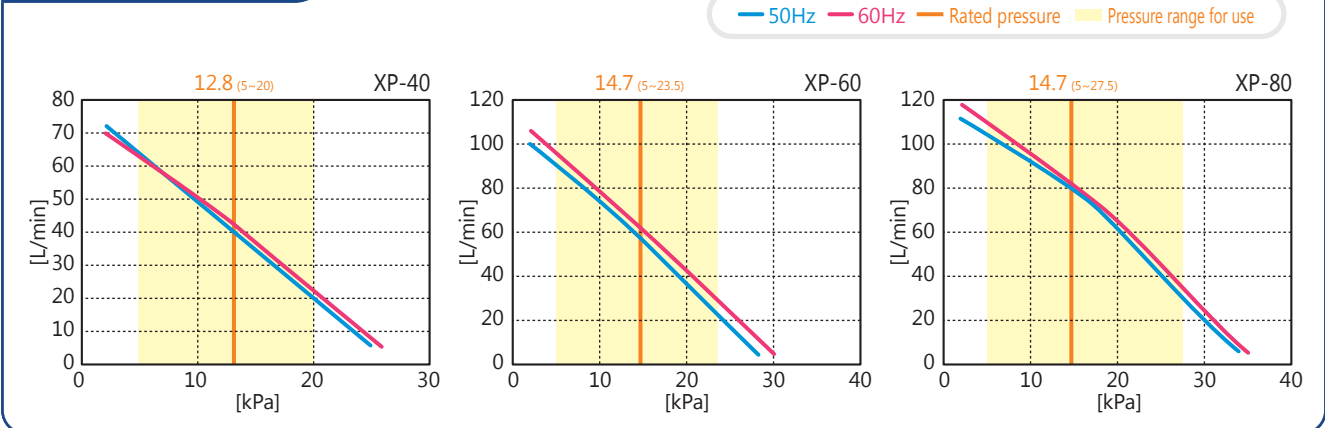

\* All characteristics values are only for reference, and are not guaranteed values.  
\* Note that the operating temperature for our pumps is 41°F(5°C) to 104°F(40°C).