

Medium capacity air pump
DUO-60/80



- Pressure type
- Easy restart by micro switch
- Two directional control valve
- No need of grounding
- Outdoor (Rainproof) use

Applications

- Septic tank (biological contact aeration)
- Air injection for bubble bath
- Small capacity compressor

Dimensions

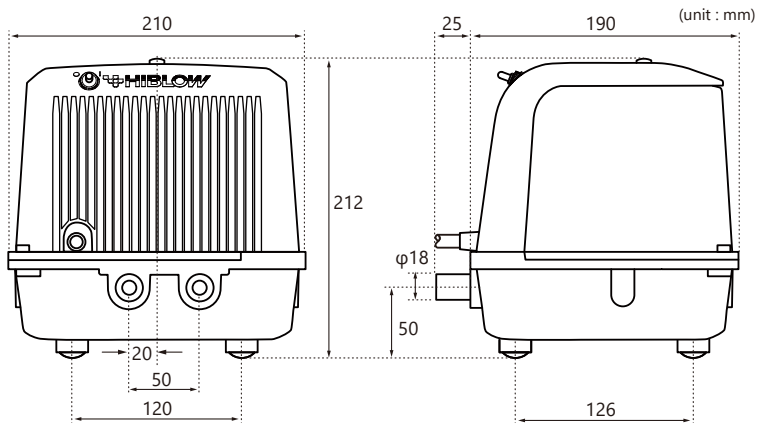

Specifications

	DUO-60		DUO-80	
Rated voltage [V]	AC120 / 230			
Power frequency [Hz]	50	60	50	60
Rated pressure [kPa]	14.7			
Airflow volume [L/min]	60		80	
Power consumption [W]	39		58	
Sound level [dBA]	35			
Weight [kg]	6			

Performance Curve

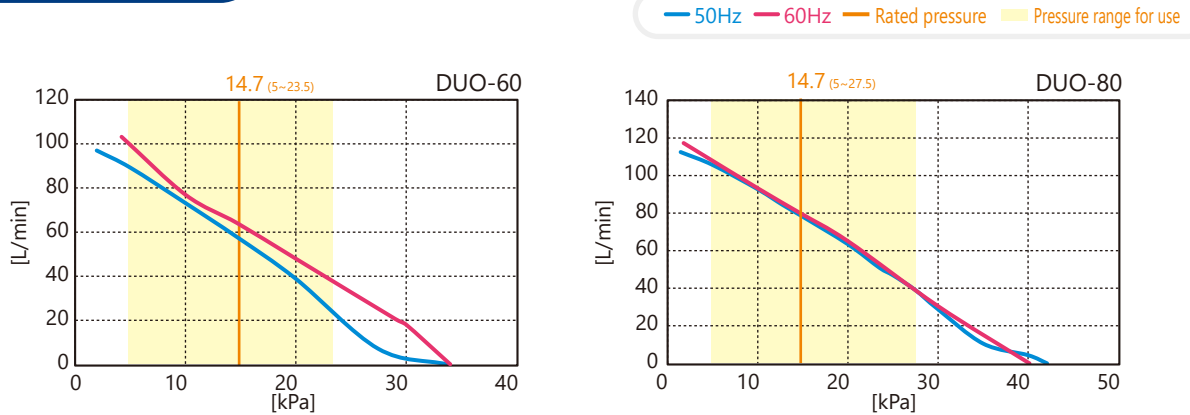

* All characteristics values are only for reference, and are not guaranteed values.
* Note that the operating temperature for our pumps is 41°F(5°C) to 104°F(40°C).