

Large capacity air pump HP-100LL / 120LL

HIBLOW®



- Pressure use
- Outdoor (Rainproof) use

- ### Applications
- Septic tank (biological contact aeration)
 - Air injection for bubble bath
 - Small capacity compressor
 - Oxygen supply for fish breeding

Dimensions

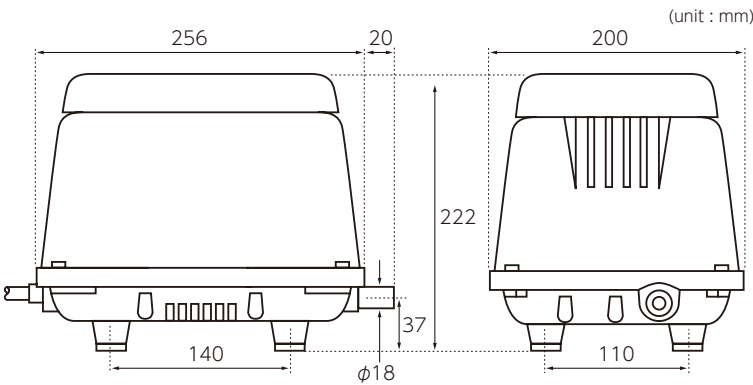

Specifications

	HP-100LL	HP-120LL
Rated voltage [V]	AC 120 / 230 / 240	
Power frequency [Hz]	50 60	50 60
Rated pressure [kPa]	17.7	
Airflow volume [L/min]	100	120
Power consumption [W]	75	90 100
Sound level [dBA]	42	
Weight [kg]	9.0	

Performance Curve

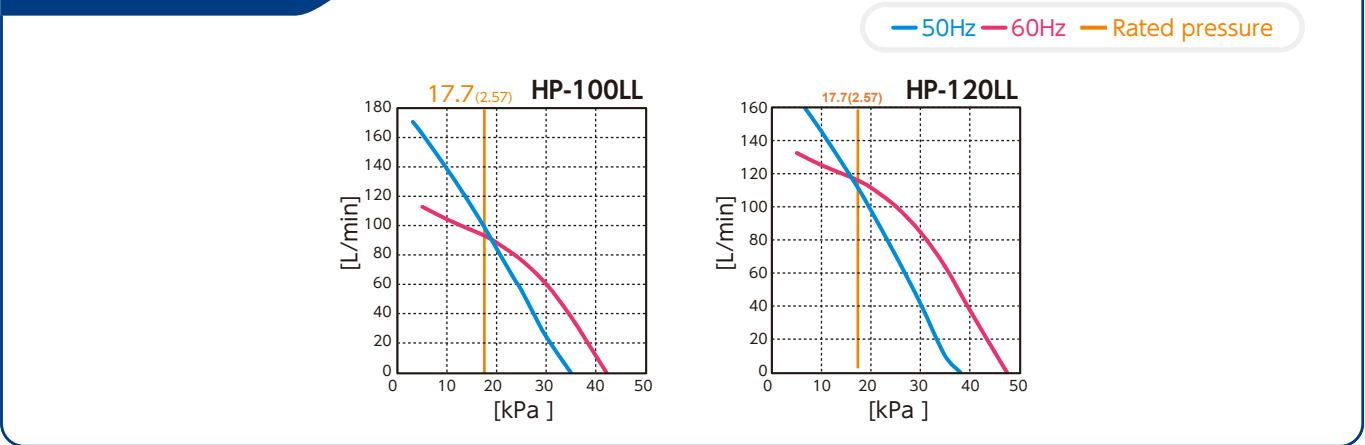

* All characteristics values are only for reference, and are not guaranteed values.
 * Note that the operating temperature for our pumps is 41°F(5°C) to 104°F(40°C)

HIBLOW AUSTRALIA PTY LTD

HIBLOW USA INC HIBLOW FRANCE S.A.S HIBLOW EUROPE S.L. HIBLOW GREINWORTH (SUZHOU) CO., LTD.

For more information and contact

HIBLOW AUSTRALIA

or Call : **02-9457-8622**

