

medium capacity air pump

# HP-80+



Pressure type

Outdoor (Rainproof) use

## Applications

- Low frequency therapeutic equipment and other medical & scientific apparatus
- Septic tank (biological contact aeration)
- Bubble bath (air bubble injection)
- Oxygen supply for fish breeding

## Dimensions

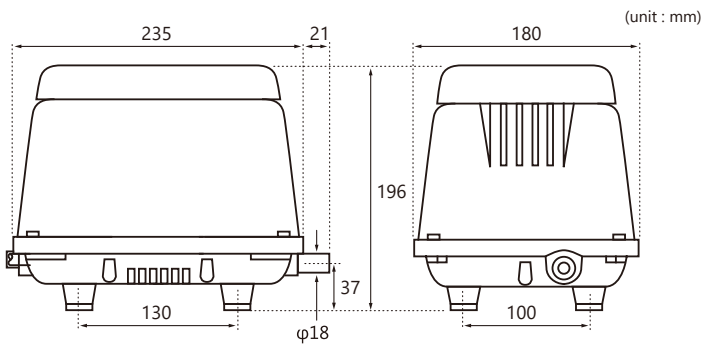

## Specifications

	HP-80+
Rated voltage [ V ]	AC240
Power frequency [ Hz ]	50
Rated pressure [ kPa ]	17
Airflow volume [ L/min ]	90
Power consumption [ W ]	77
Weight [ kg ]	7

## Performance Curve

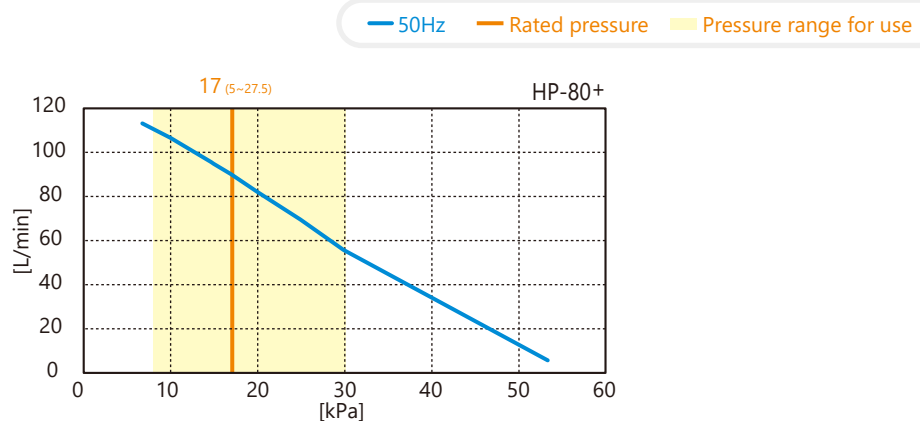

\* All characteristics values are only for reference, and are not guaranteed values.  
\* Note that the operating temperature for our pumps is 41°F(5°C) to 104°F(40°C).